

DATE: October 14, 1997
Lab #: 97-479**The Safron Corporation**
12932 S.W. 130 Street
Miami, FL 33186**RE: Report on Safety Rail Load Test Observations**
The Safron Corporation
Series P-340 Pool Rail, a Pool Safety Handrail (2' 11" Height)
ATC Project #: 90931.0064

Gentlemen:

In accordance with the request and authorization of The Safron Corporation, on October 8, 1997 a representative of ATC Associates Inc. observed the safety rail load test of the Safron Series P-340 Pool Rail, a 2 feet 11 inch tall pool safety handrail, at Safron's Miami facility.

TESTING

The handrail load test was conducted on October 8, 1997 at about 8:40 AM at Safron's Miami, Florida facility. The test was conducted by Robert Weiss of The Safron Corporation and witnessed by Mr. Laughn M. Drouillard of ATC Associates Inc. Also present was Mr. Marshall Hickman of The Safron Corporation.

TESTING PROCEDURE

The test sample was a typical series P-340 Figure Four Handrail produced by Safron. The tested handrail was constructed of polyvinyl chloride, PVC a non-conductive material. The physical demensions of the PVC pipe was 1.90" OD, 1.38" ID, and a wall thickness of 0.26". The handrail was installed in a concrete slab as noted on the included detail sheet. The test loads were measured using a calibrated electronic dynamometer with a 1,000 pounds (lbs.) electronic transducer load cell. The load was applied to the sample by means of a steel chain attached to the sample rail on one end and to the load cell on the other end, then a 5,000 lbs. tension crank, (come-along) was attached to the other side of the load cell which was then attached to the reaction load, a fork lift by another steel chain.

Loads were applied to the sample at the peak of the handrail for testing. For this test an initial measurement was taken from the center of the top rail at the loading point to a reference point

P-326

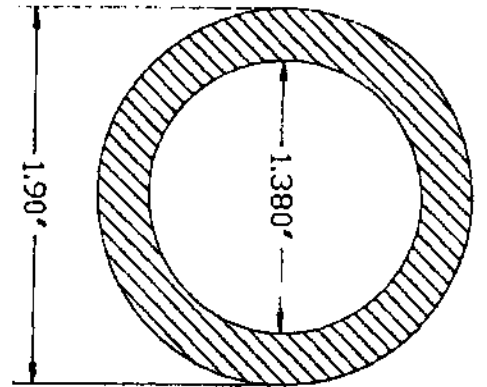
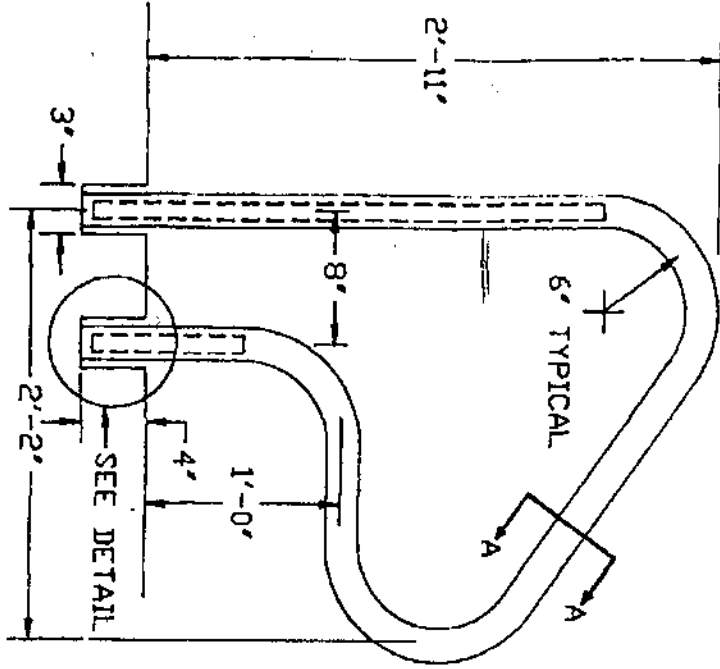

PIPE, HIGH IMPACT
U.V. STABILIZED PVC
FOR HANDRAILS
WALL THICKNESS 0.26"

CROSS SECTION "A-A"

DETAIL

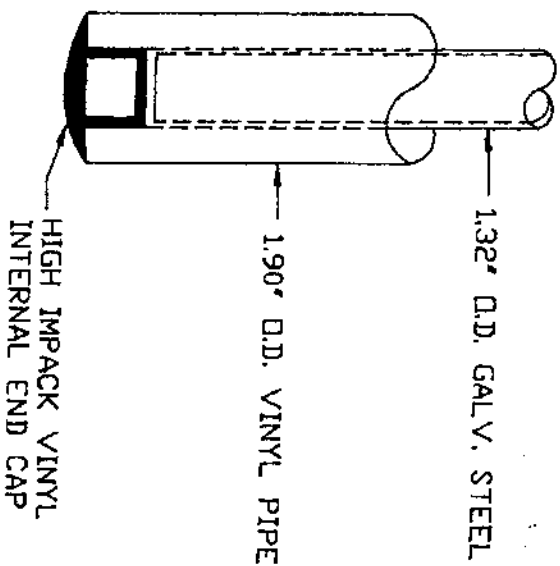

 VINYL PLASTIC SAFETY RAILINGS	PROJECT:	
	SUBJECT:	
GAFTROIT CORPORATION 12391 G.W. 130TH STREET MIAMI, FLORIDA 33186 305-233-5511 FAX-251-8826	PREPARED BY:	
	CHECKED BY:	SCALE:
	APPROV. BY:	DRAW. NO.

established by a steel post located behind the sample rail. A load of 250 lbs. was then applied to the test sample and a deflection measurement was taken. The load was held at 250 lbs. for 5 minutes at which time another deflection measurement was taken. The load was then removed and a final deflection measurement was taken to determine the rebound.

Included are diagrams showing the rail system and anchoring detail supplied by The Safron Corporation. Following is the data observed at the time of testing:

LOAD TEST FOR SERIES P-326 FIGURE FOUR HANDRAIL		
LOAD (lbs.)	DEFLECTION (in.)	NOTES
load applied at peak of handrail		
0	0	no load applied
250	3/8	@ full load
250	3/8	@ full load after 5 min.
0	0	rebound
load applied at peak of handrail		
0	0	no load applied
400	2 1/8	@ full load
400	2 1/8	full load after 5 min.
0	7/8	rebound

Thank you for the opportunity to be of service. Please call should you have any questions.

Respectfully submitted,
ATC Associates Inc.

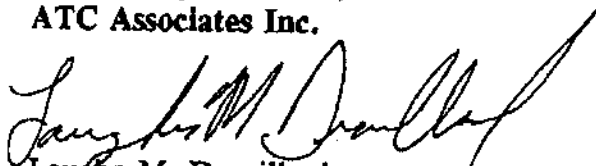
Laughn M. Drouillard
Operations Supervisor

Peter G. Read, P.E.
Division Manager

DATE: October 14, 1997

Lab #: 97-478

The Safron Corporation
12932 S.W. 130 Street
Miami, FL 33186

RE: *Report on Safety Rail Load Test Observations*
The Safron Corporation
Series P-326 Figure Four Handrail, Pool Safety Rail (35" Height)
ATC Project #: 90931.0064

Gentlemen:

In accordance with the request and authorization of The Safron Corporation, on October 8, 1997 a representative of ATC Associates Inc. observed the safety rail load test of the Safron Series P-326 Figure Four Handrail, a 35 inch tall pool safety rail, at Safron's Miami facility.

TESTING

The handrail load test was conducted on October 8, 1997 at about 8:00 AM at Safron's Miami, Florida facility. The test was conducted by Robert Weiss of The Safron Corporation and witnessed by Mr. Laughn M. Drouillard of ATC Associates Inc. Also present was Mr. Marshall Hickman of The Safron Corporation.

TESTING PROCEDURE

The test sample was a typical series P-326 Figure Four Handrail produced by Safron. The tested handrail was constructed of polyvinyl chloride, PVC a non-conductive material. The physical demensions of the PVC pipe was 1.90" OD, 1.38" ID, and a wall thickness of 0.26". The handrail was installed in a concrete slab as noted on the included detail sheet. The test loads were measured using a calibrated electronic dynamometer with a 1,000 pounds (lbs.) electronic transducer load cell. The load was applied to the sample by means of a steel chain attached to the sample rail on one end and to the load cell on the other end, then a 5,000 lbs. tension crank, (come-along) was attached to the other side of the load cell which was then attached to the reaction load, a fork lift by another steel chain.

Loads were applied to the sample at the peak of the handrail for testing. For this test an initial measurement was taken from the center of the top rail at the loading point to a reference point

established by a steel post located behind the sample rail. A load of 250 lbs. was then applied to the test sample and a deflection measurement was taken. The load was held at 250 lbs. for 5 minutes at which time another deflection measurement was taken. The load was then removed and a final deflection measurement was taken to determine the rebound.

Included are diagrams showing the rail system and anchoring detail supplied by The Saftron Corporation. Following is the data observed at the time of testing:

LOAD TEST FOR SERIES P-340 POOL RAIL		
LOAD (lbs.)	DEFLECTION (in.)	NOTES
load applied at peak of handrail		
0	0	no load applied
250	7/8	@ full load
250	7/8	@ full load after 5 min.
0	0	rebound
load applied at peak of handrail		
0	0	no load applied
400	3 3/8	@ full load
400	3 3/8	full load after 5 min.
0	2	rebound

Thank you for the opportunity to be of service. Please call should you have any questions.

Respectfully submitted,
ATC Associates Inc.

Laughn M. Drouillard
Operations Supervisor

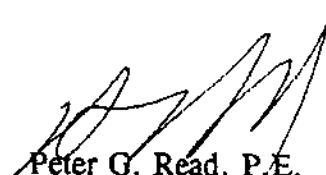
Peter G. Read, P.E.
Division Manager

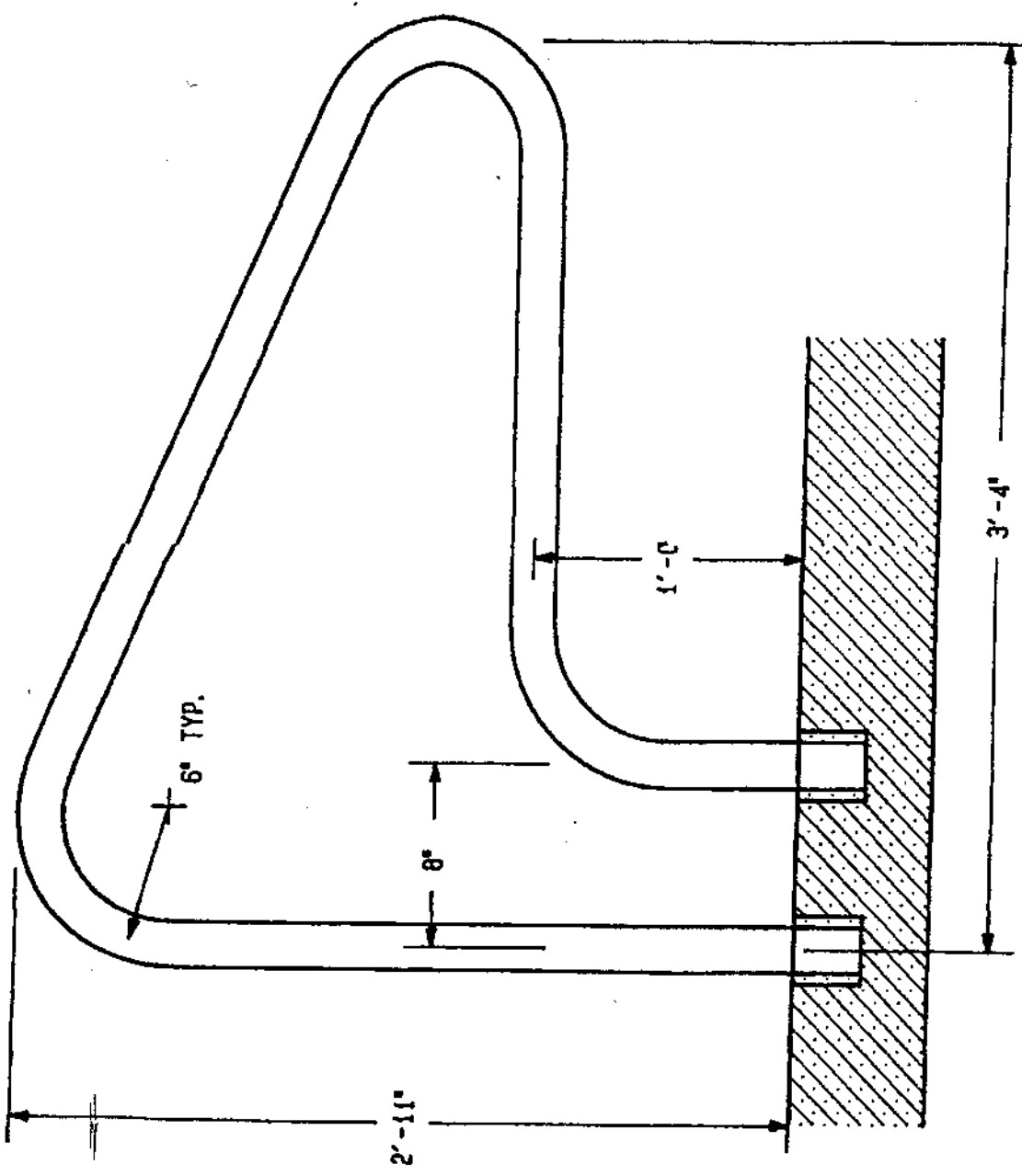

PROJECT: VARIEG

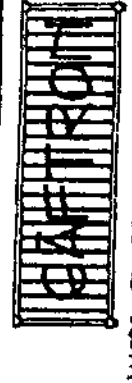

THE GAFFRATHAN CORPORATION
 12391 S.W. 130TH STREET
 MIAMI, FLORIDA 33186
 305-253-5511 FAX-251-8826

SUBJECT: TYPICAL SERIES P-340 POOL RAILING

PREPARED BY: BOB GRANTHART

APPROV. BY:

TITLE :

CADD P/L : POOL-2
 ISSUED : 01/17/96
 SCALE : 1-1/2" = 1 FT.
 DRAW. NO. P-340